

Suitable for medium & large workpiece. (Can do 5 sides machining)



Patented
Taiwan M258824, Italy,
USA us7, 224, 251, B2
Japan 3106264, Korea 0366170,
Germany 20 2004 009 776.1
China ZL2004 2 0067865.1

Standard Accessories: Handle -----1 set Induction soft block -----1 set Stopping plate -----1 set Guide key -----2 pcs Switch connector -----1 set	Induction soft block 
Handle 	Guide key 
Stopping plate 	Switch connector 

Features:

1. The all new model Magnetic Clamping Block ECB Series are a new sense of clamping way for metal working on CNC Machining Center and Milling Machine in quick clamp workpieces.
2. Free to set up position, numbers and distance of Magnetic Clamping Block according to the size of workpiece.
3. The ECB Series including changeable Induction Soft Block It can be revised the surface to be 100% accuracy on the machine for clamp workpieces. Can be also cutting, drilling, tapping and slotting directly to the Induction Soft Block during machining workpiece. Multi-function of Induction Soft Block, the user can make it by themselves according to workpiece required.
4. Two machining circle for finish workpiece machining, increase a lot of machining efficiency and achieve accuracy required.

Applications:

1. Most suitable for medium and large size of workpiece machining on milling machine and CNC machining center.
2. Minimum size of workpiece required as bigger than an area of two Magnetic Clamping Blocks.
3. The Magnetic Clamping Blocks are not suitable for small workpiece clamping.

Note:

1. Please always make sure the Switch was in ON position before machining.
2. The Magnetic Clamping Blocks are not suitable for non-magnetic material, such as brass, copper, aluminum and stainless steel, etc.
3. The principle of Magnetic Clamping Blocks is magnetism of N. S. poles, so please always put the workpiece between N. S. poles. (The middle of top clamping range)

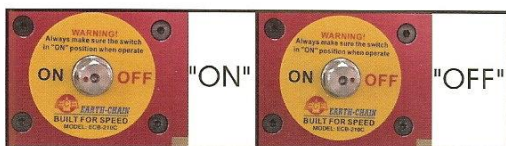

Working Example

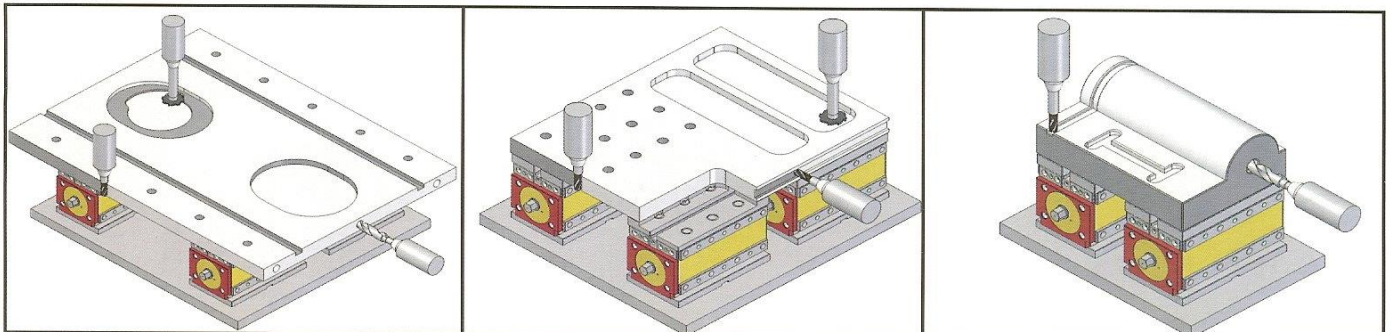

MODEL NO.	HOLDING POWER	MINIMUM THICKNESS OF WORKPIECE REQUIRED	G	G = +0 -0.03	H	H = +0 -0.03	N.W
ECB-210	2100kgf	30	115	Accuracy control required	134	Accuracy control required	36kg
ECB-120	1200kgf	20	94.5		108		18kg
ECB-075	750kgf	15	88		78		9.5kg
ECB-050	500kgf	15	61		78		7kg

Suitable for medium & large workpiece. (Can do 5 sides machining)

Customer can be makes switch connector by standard hexagon steel bar themselves for depends on length required. The dimension of hexagon bar required as ECB-210 --- 19mm, ECB-120, 075, 050 --- 13mm.



Maximum & Minimum distance required

Unit:mm

MODEL NO.		ECB-210	ECB-120	ECB-075	ECB-050
SIDE DISTANCE	Min.	100	60	25	25
	Max.	1000	600	400	400
FRONT & BACK DISTANCE	Min.	70	40	40	40
	Max.	500	300	200	200

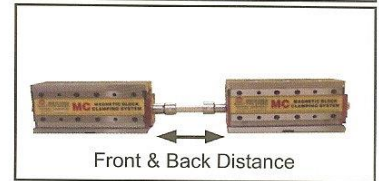
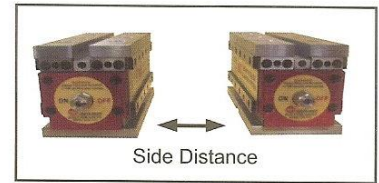

Working Example



Special made Induction Block:

Customer can makes special induction block themselves for depends on the workpiece and application required.

(The material of induction block required as general and low carbon steel)

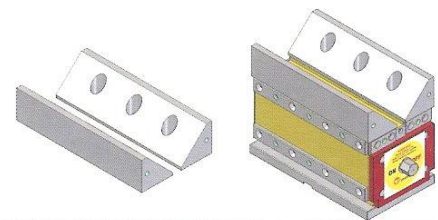

Example

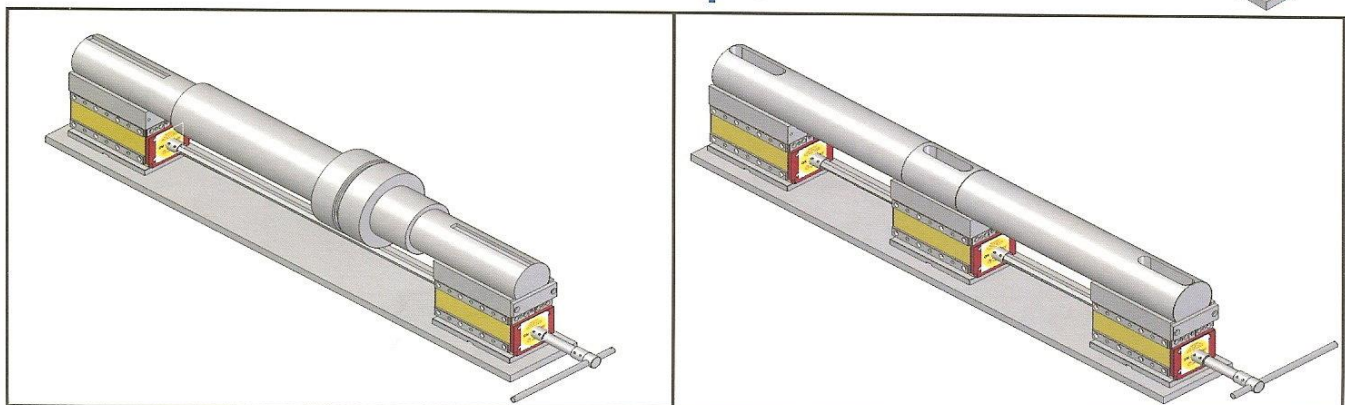

Permanent Magnetic Clamping Block ECB-120V12

Suitable for use on CNC Horizontal Machining Center. (Can do 5 sides machining)

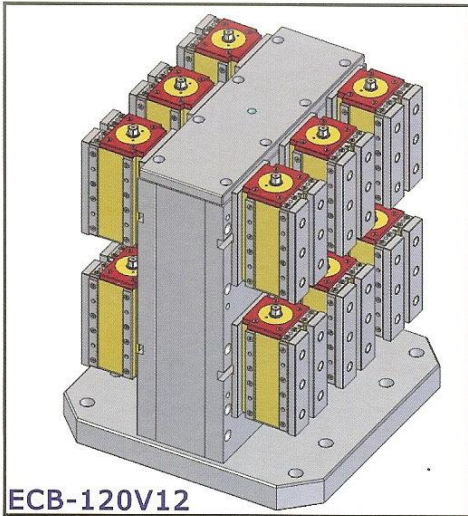

ECB-120V12

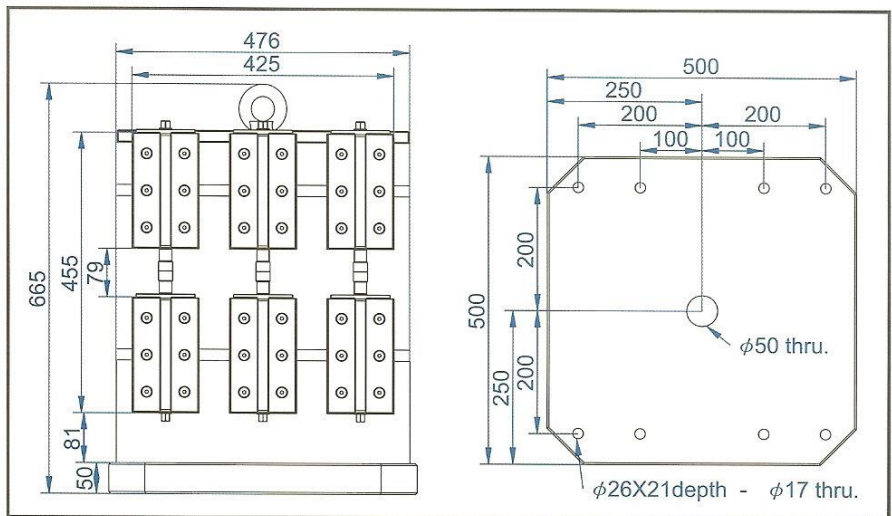

Features & Applications:

1. Each 6pcs of ECB-120 magnetic clamping block on 2 working face, each of 7200kgf (1200kgf \times 6) holding power, can be clamping 2 big workpieces for machining at same time.
2. Customer can makes and assemble any type of clamping device themselves by ECB series for depends on workpieces required.
3. Suitable for use on CNC Horizontal Machining Center. (can do 5 sides machining.)

Working Example

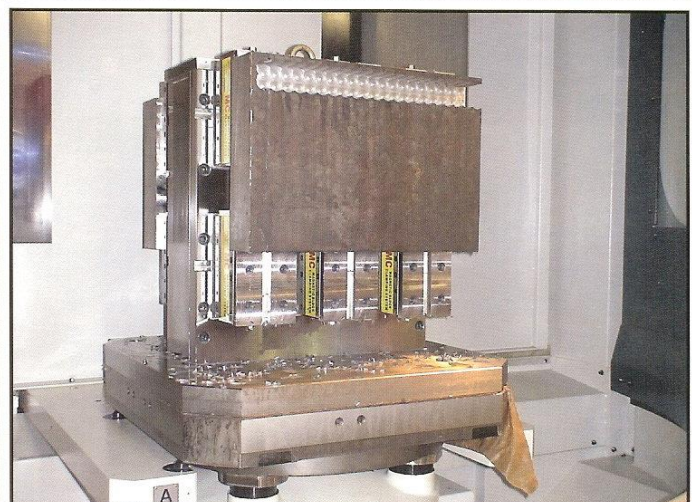

Custom-made is available.

Dimension ECB-210

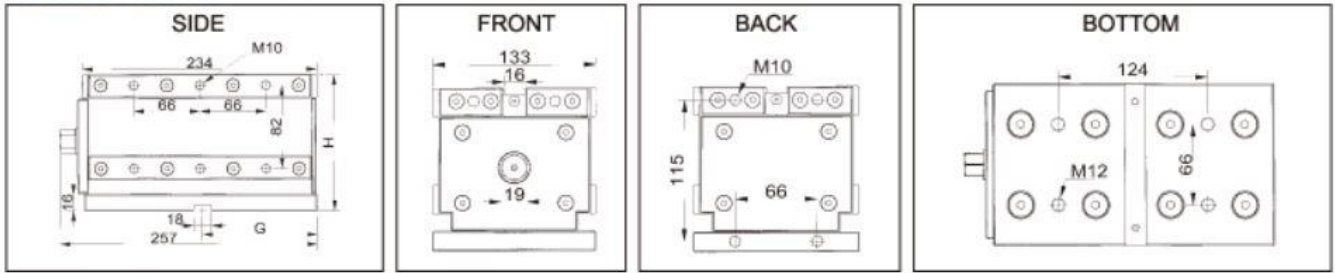

ECB-120

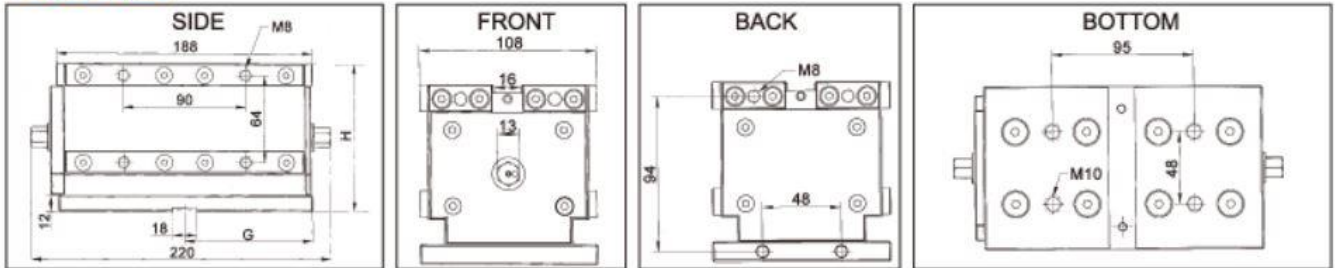

ECB-075

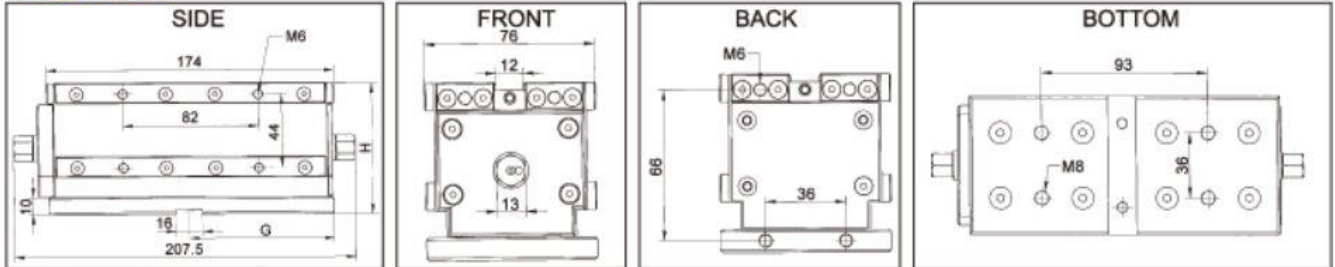

ECB-050

